



Manufactured by:
Backyard Discovery
3305 Airport Drive, Pittsburg, KS
66762 800-856-4445

Basepoint Business Centre: Rivermead Drive, Westlea, Swindon SN5 7EX Phone: 0800-118-2476 J.P. Coenstraat 7, The Bridge, The Hague, 2595 WP, Netherlands Phone: 08005678990

TEAK PLANTER

MODEL # : 2204065

THE ASSEMBLY MANUAL MUST BE RETAINED SINCE
IT CONTAINS IMPORTANT INFORMATION



Please visit www.backyarddiscovery.com
For the most up to date assembly manual, to register your product, or to order
replacement parts *Para obtener instrucciones en español, visite*
www.backyarddiscovery.com



**INSTALLATION
SERVICES
AVAILABLE!**
See inside for details

OWNER'S MANUAL - BASIC SETUP DIMENSIONS & ASSEMBLY NOTES

It is critically important that you start with square and level footings, concrete pad or deck to attach your structure

- Pay close attention to the items needed for each step. Make sure you are using the correct hardware for each step. Using incorrect hardware may result in improper assembly

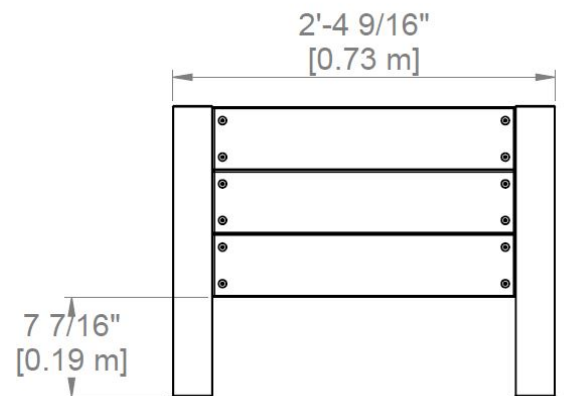
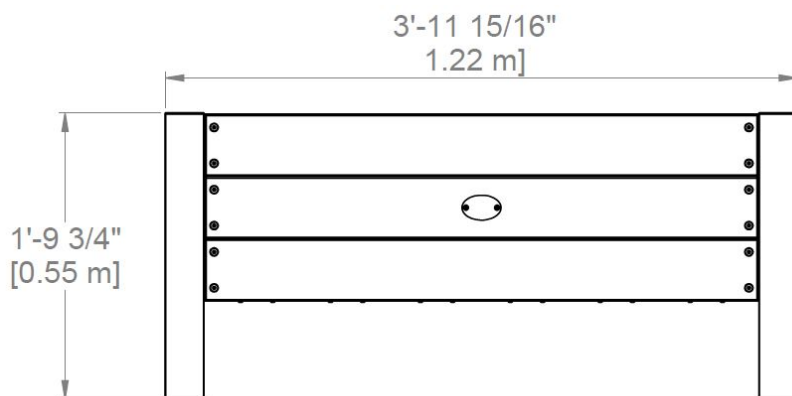
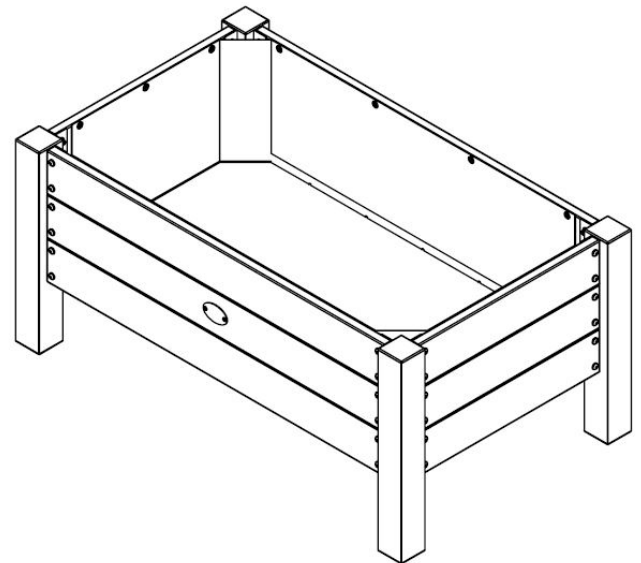
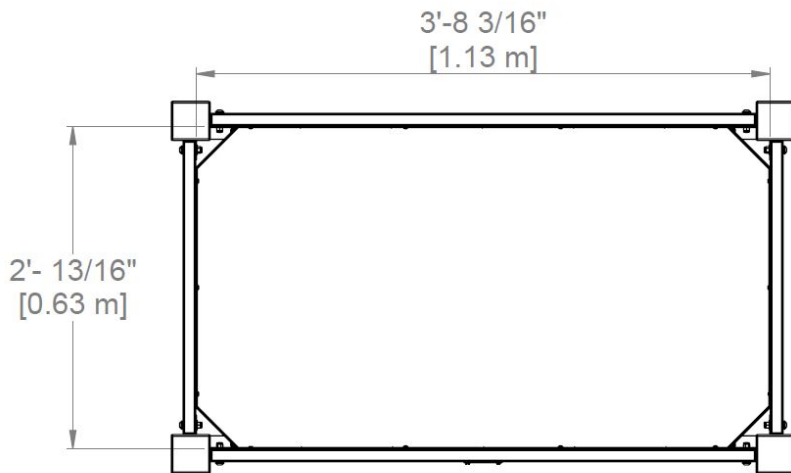

OWNER'S MANUAL - PARTS IDENTIFICATION

Wood Components (Not to Scale)



G01 | LONG SIDE BOARD-W4L16326
(x6) | 7/8"x4 3/4"x41 15/16" (22x120x1066)



G02 | SHORT SIDE BOARD-W4L16327
(x6) | 7/8"x4 3/4"x22 5/8" (22x120x574)



G03 | SLAT-W4L16328
(x6) | 7/8"x4 3/4"x24 1/2" (22x120x623)

Accessory Components (Not to Scale)

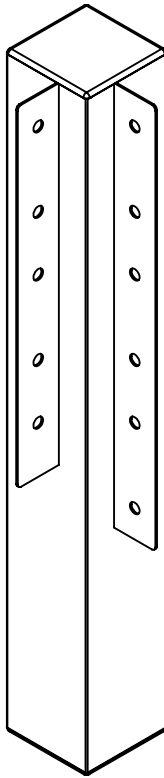

A4M01533 | POST ASSEMBLY
(x2)

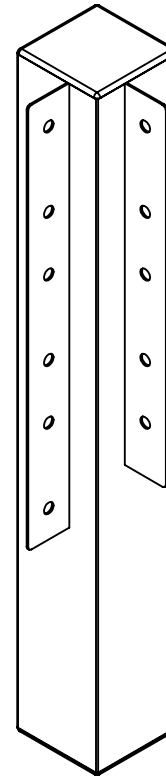

A4M01534 | POST ASSEMBLY
(x2)

OWNER'S MANUAL - PARTS IDENTIFICATION

Accessory Components (Not to Scale)

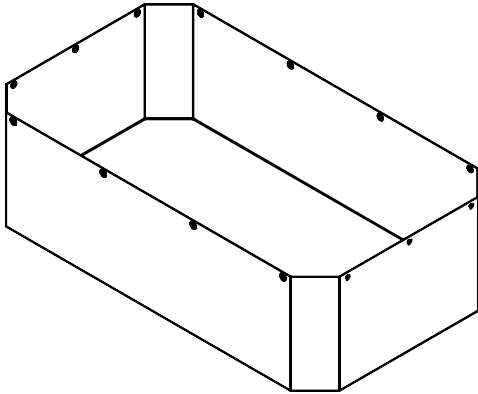

A6P00511
(x1) | **PLANTER LINER**

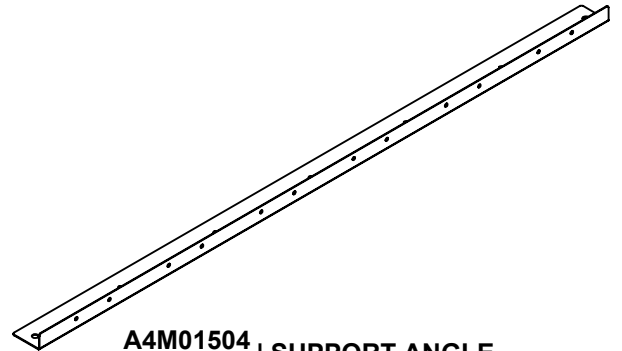

A4M01504
(x2) | **SUPPORT ANGLE**

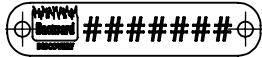

A4M01229
(x1) | **PRODUCT NUMBER TAG**



A100241
(x1) | **BYD ID TAG**

Hardware Components (Not to Scale)



H100202 | **SCREW PWH BLK**
(x50) | 8 x 5/8



H100127 | **SCREW PPH BLK**
(x2) | 4 x 5/8

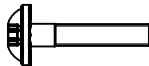

H100397 | **BOLT WH BLK**
(x48) | 1/4 x 1 1/4



H100653 | **NUT LOCK BLK**
(x48) | 1/4



H100630 | **WASHER FLAT BLK**
(x48) | 8x19

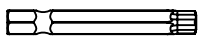

H100147 | **TORX BIT**
(x1) | T-30



H101100
(x1) | **MAGNETIC DRIVER**



H100114 | **TORX WRENCH**
(x1) | T-30

PRE-ASSEMBLY STEP 1 - TOOLS REQUIRED



Cordless Drill
or Electric Drill



Drill
Attachments:
Phillips Head



Phillips Screw Driver

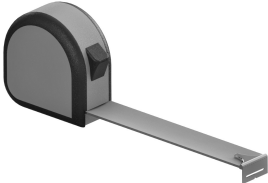

Tape Measure

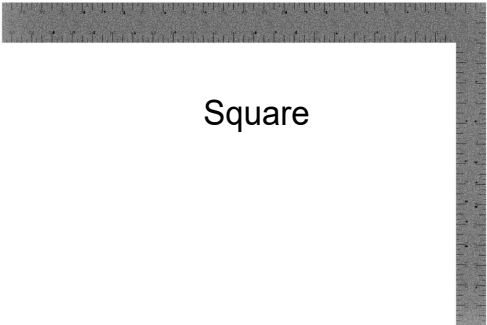

Square



Open End Wrench - 7/16"



Claw Hammer



Rubber Mallet
- Optional



Level 24"

PRE-ASSEMBLY STEP 2 - SORTING PARTS

It is critical for ease of assembly that you take the time to sort and organize the wood and hardware.

WOOD PARTS:

- Organize wood parts by the three-digit, alpha-numeric number stamped on each board (ex. P01).
- If there are multiple boards with the same stamped number, stack those pieces together.
- Stamps can be found on the flat surface of the boards or on the end of the boards.
- Allow yourself plenty of room - the wood pieces can take up a significant amount of space.

NOTE: CARTONS ARE NOT ORGANIZED BY BOARD NUMBER.



HARDWARE PARTS:

- We recommend that you have a separate table to organize the hardware.
- Hardware bags are printed with a seven-digit, alpha-numeric part number.
- You can organize your hardware by part number or group by hardware type (i.e. bolts, nuts, etc.).
- During assembly you only need to reference the last four digits of the number.

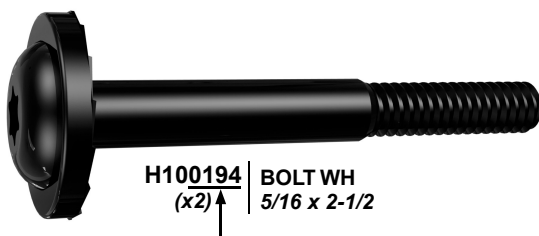

H100194 | BOLT WH
(x2) ↑ 5/16 x 2-1/2

STEP 1 - PLANTER ASSEMBLY

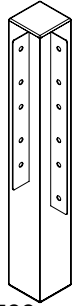

A4M01533
(x2) | POST ASSEMBLY

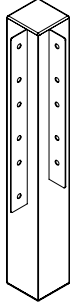

A4M01534
(x2) | POST ASSEMBLY



G02 | SHORT SIDE BOARD-W4L16327
(x6) | 7/8"x4 3/4"x22 5/8" (22x120x574)

QTY	PART NUMBER	DESCRIPTION
24	H100653	NUT LOCK 1/4 BLK
24	H100397	BOLT WH 1/4x1 1/4 BLK
24	H100630	WASHER FLAT 8x19 BLK

REPEAT THIS STEP TWICE

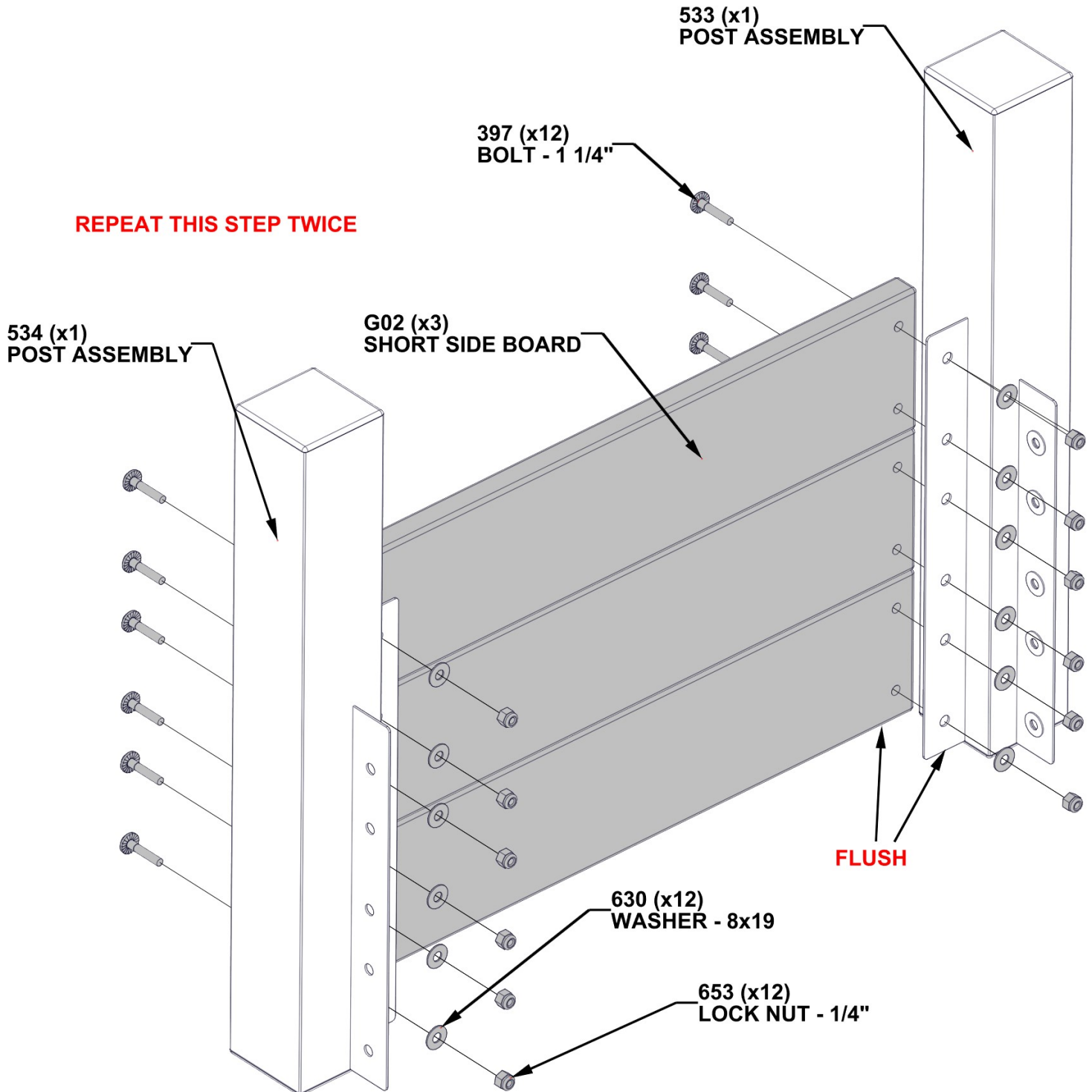

STEP 2 - PLANTER ASSEMBLY



G01| LONG SIDE BOARD-W4L16326
 (x2)| 7/8"x4 3/4"x41 15/16" (22x120x1066)

QTY	PART NUMBER	DESCRIPTION
8	H100653	NUT LOCK 1/4 BLK
8	H100397	BOLT WH 1/4x1 1/4 BLK
8	H100630	WASHER FLAT 8x19 BLK

397 (x8)
 BOLT - 1 1/4"

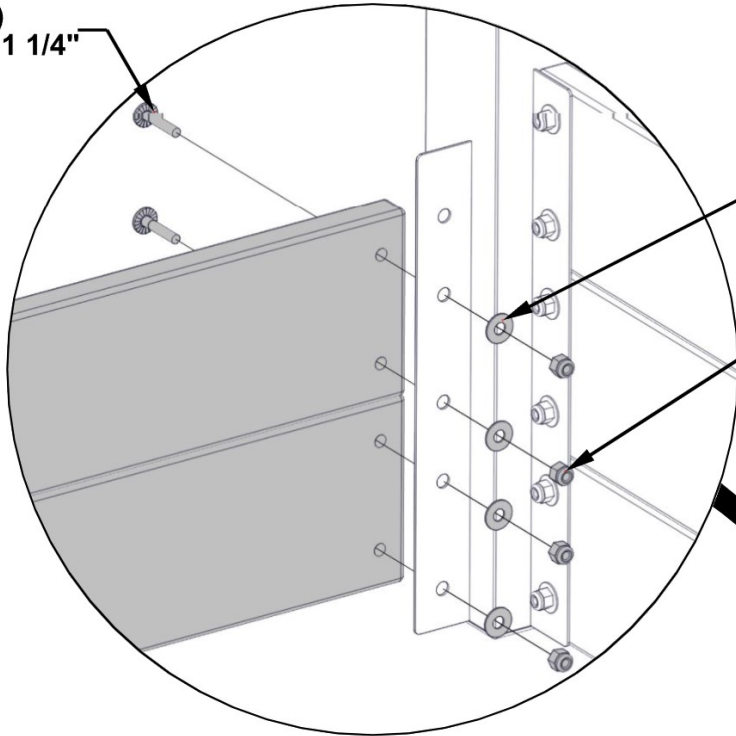

NOTE: HAND TIGHTEN SIDE BOARD TO POST ONLY.

630 (x8)
 WASHER - 8x19

653 (x8)
 LOCK NUT - 1/4"

G01 (x2)
 LONG SIDE BOARD

FLUSH

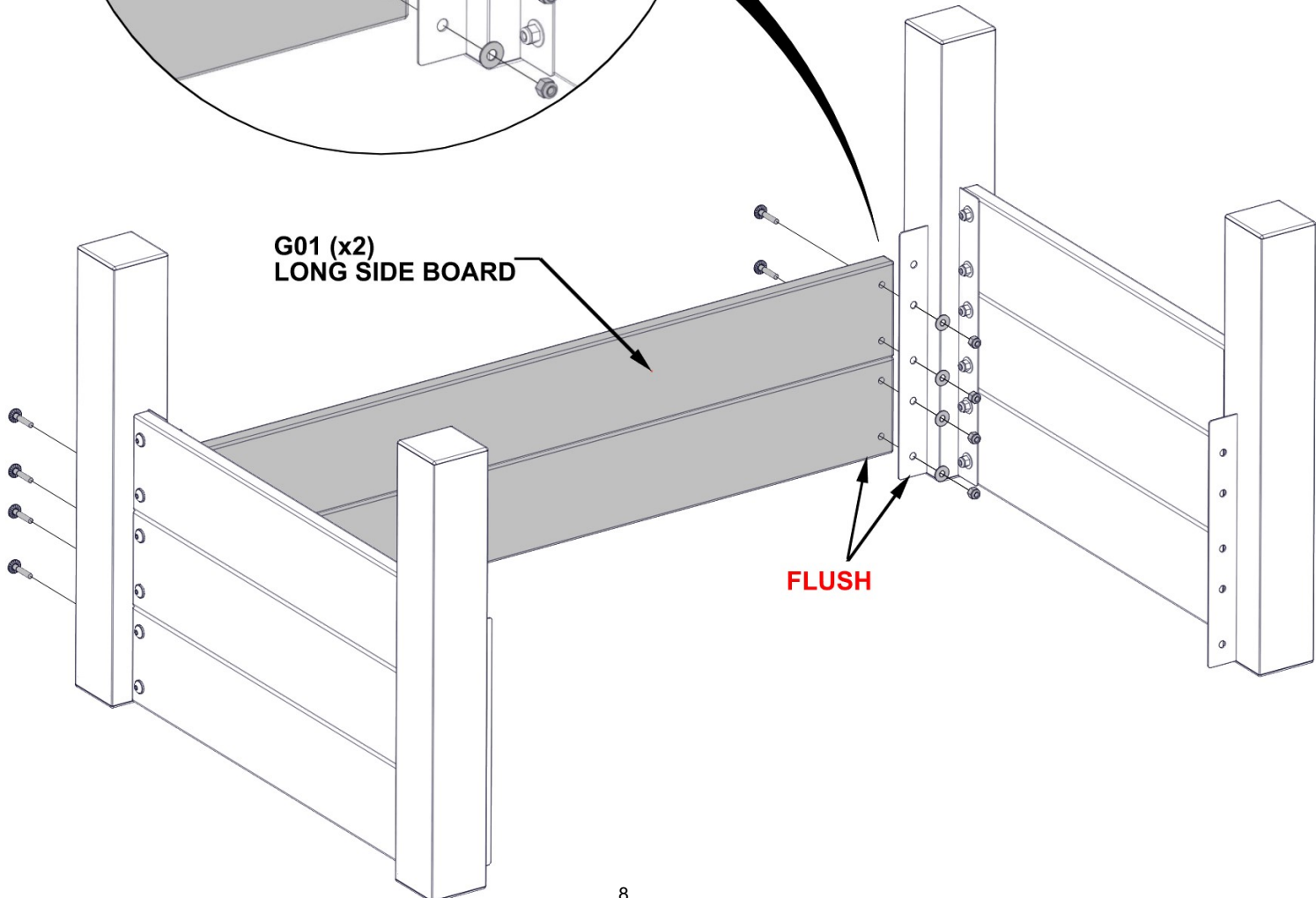

STEP 3 - PLANTER ASSEMBLY



G01 | LONG SIDE BOARD-W4L16326
 (x2) | 7/8"x4 3/4"x41 15/16" (22x120x1066)

QTY	PART NUMBER	DESCRIPTION
8	H100653	NUT LOCK 1/4 BLK
8	H100397	BOLT WH 1/4x1 1/4 BLK
8	H100630	WASHER FLAT 8x19 BLK

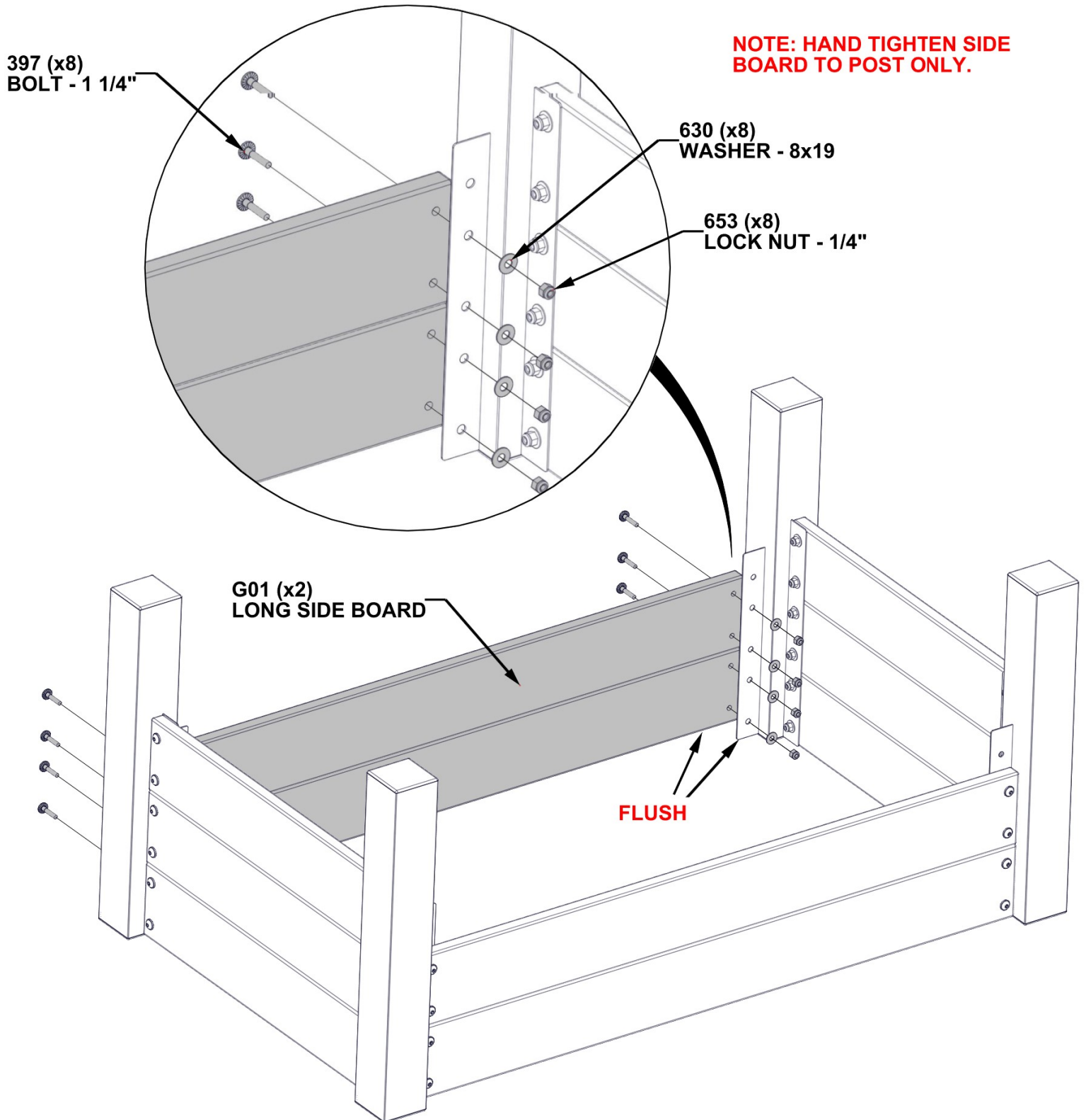

STEP 4 - PLANTER ASSEMBLY



G01 | LONG SIDE BOARD-W4L16326
 (x1) | 7/8"x4 3/4"x41 15/16" (22x120x1066)

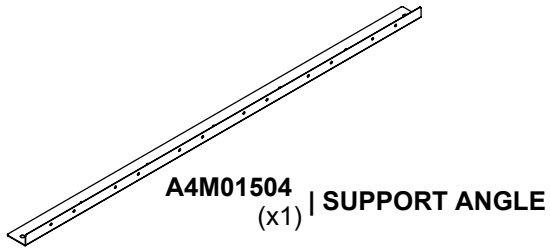

QTY	PART NUMBER	DESCRIPTION
4	H100653	NUT LOCK 1/4 BLK
4	H100397	BOLT WH 1/4x1 1/4 BLK
4	H100630	WASHER FLAT 8x19 BLK

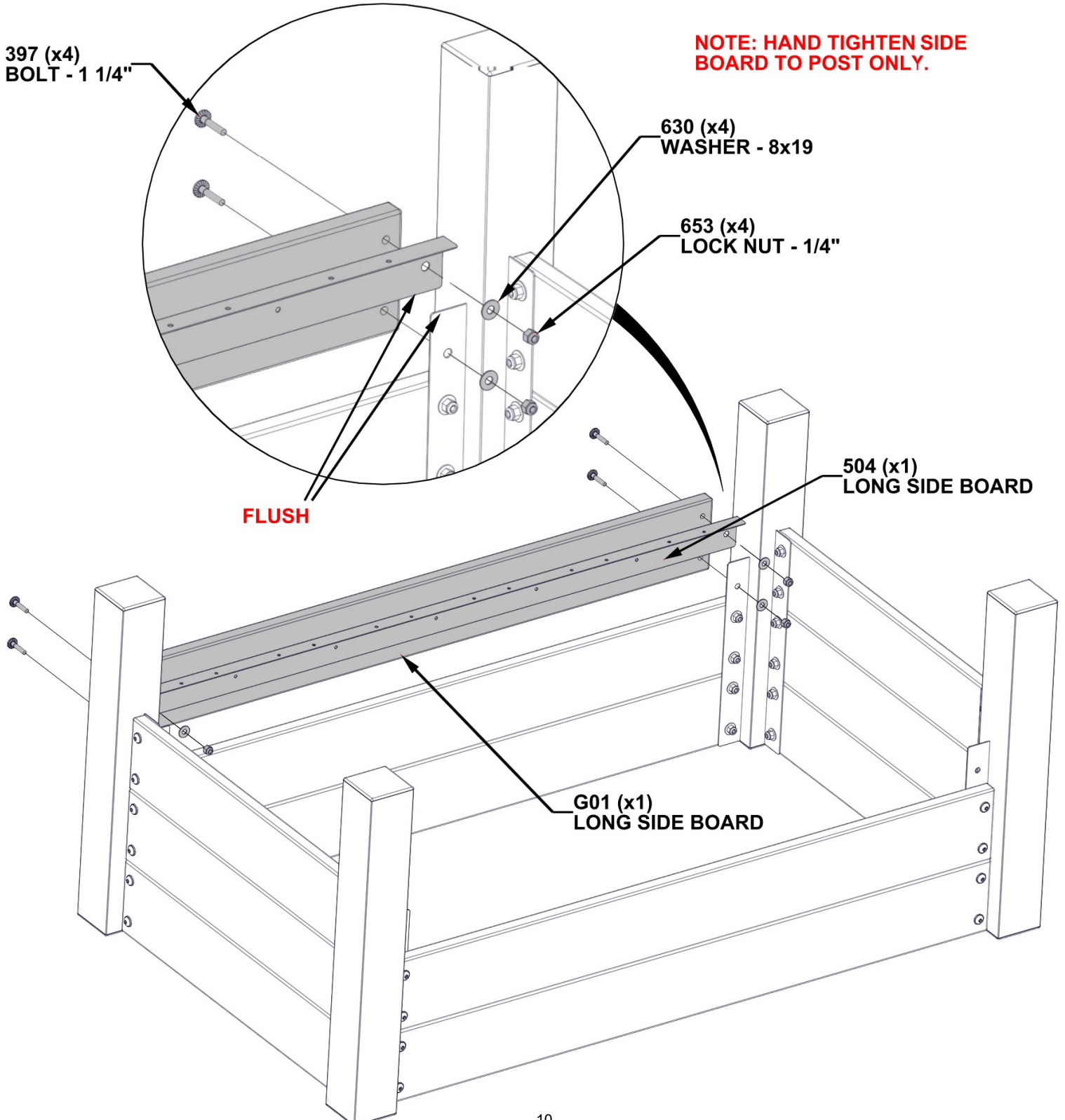

STEP 5 - PLANTER ASSEMBLY



G01 | LONG SIDE BOARD-W4L16326
 (x1) | 7/8"x4 3/4"x41 15/16" (22x120x1066)

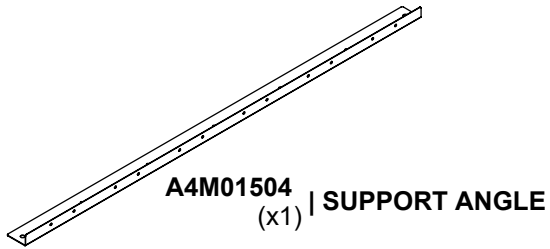

QTY	PART NUMBER	DESCRIPTION
4	H100653	NUT LOCK 1/4 BLK
4	H100397	BOLT WH 1/4x1 1/4 BLK
4	H100630	WASHER FLAT 8x19 BLK

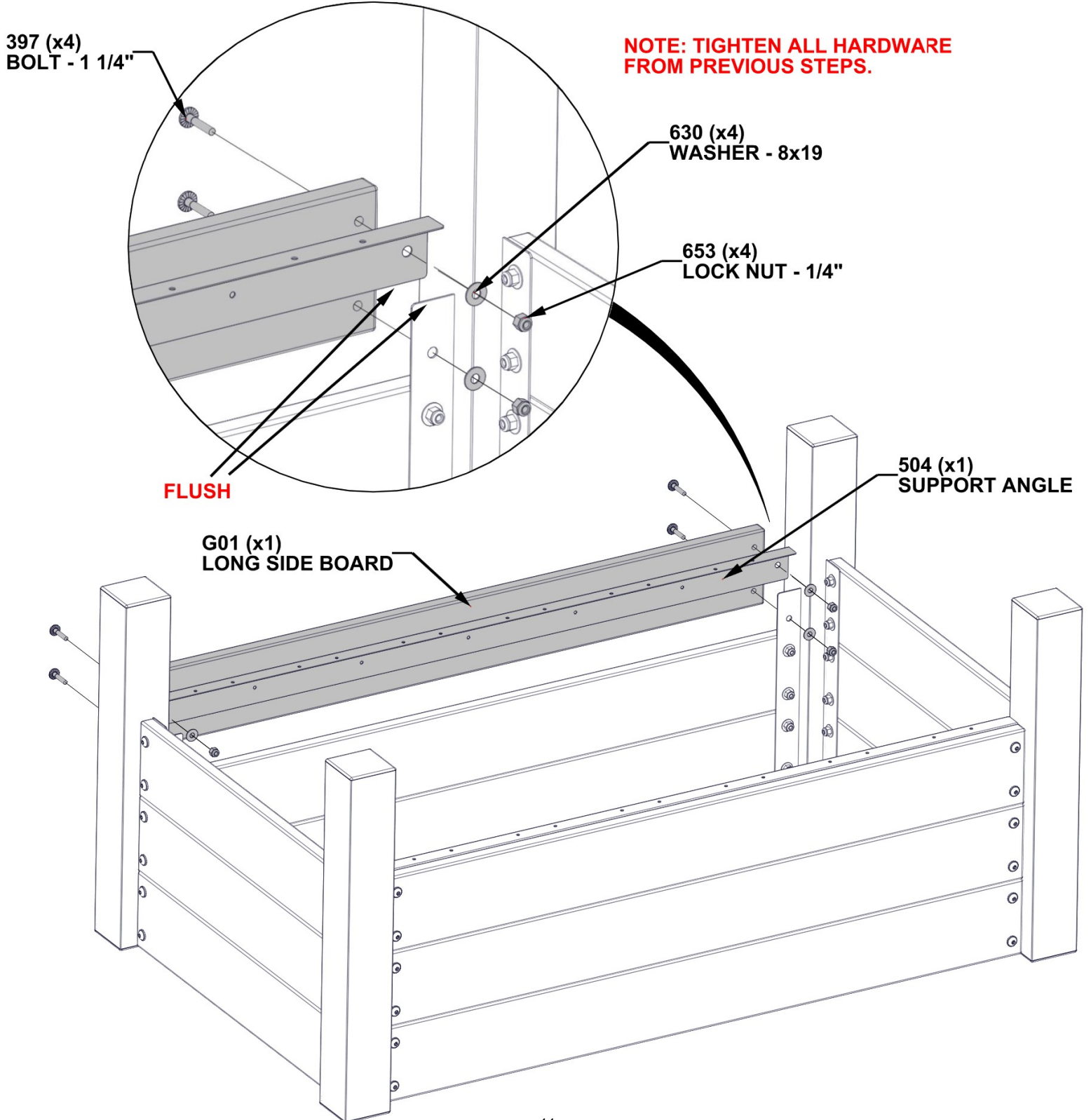

STEP 6 - PLANTER ASSEMBLY

QTY	PART NUMBER	DESCRIPTION
5	H100202	SCREW PWH 8x5/8 BLK

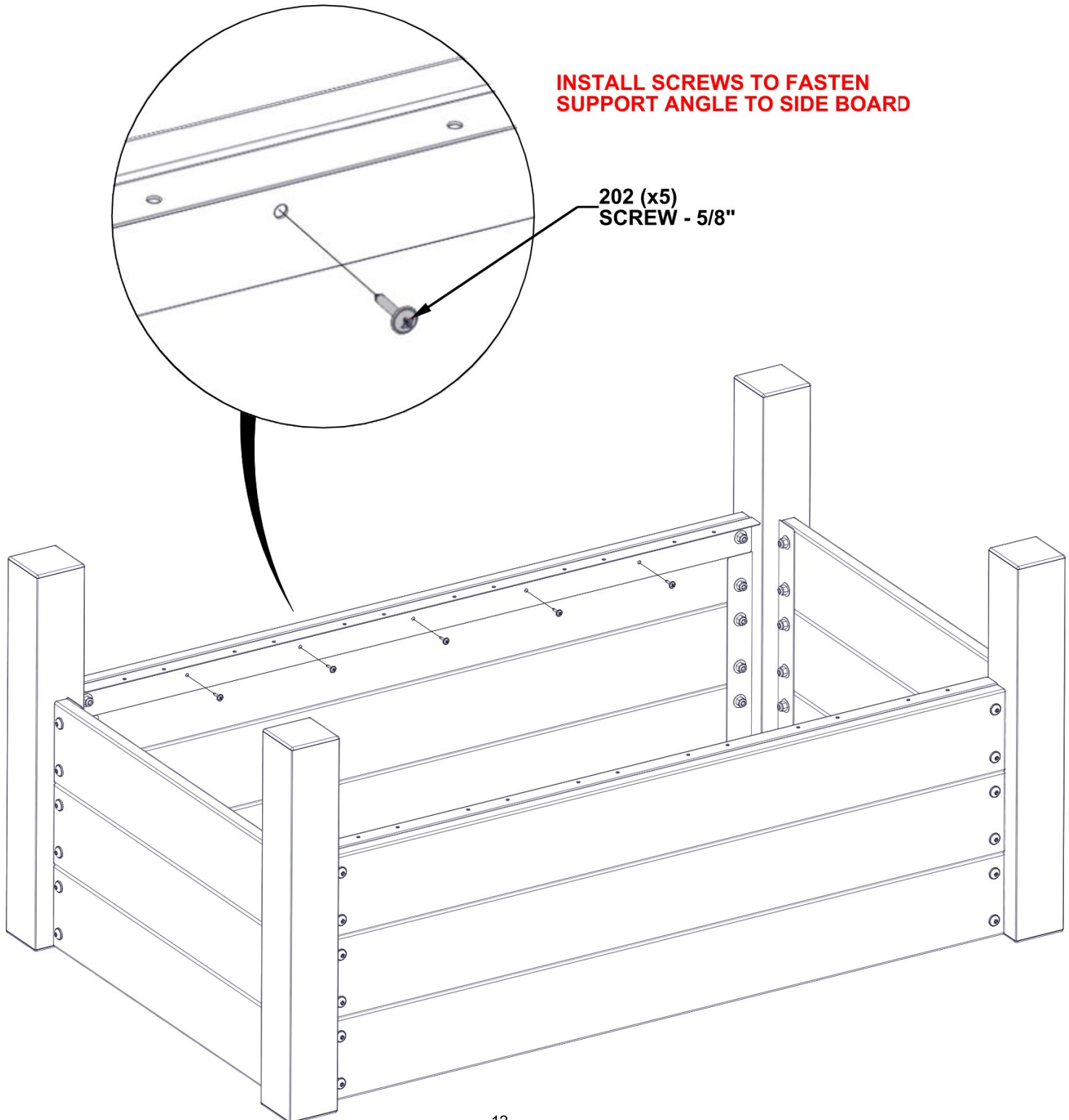

STEP 7 - PLANTER ASSEMBLY

QTY	PART NUMBER	DESCRIPTION
5	H100202	SCREW PWH 8x5/8 BLK

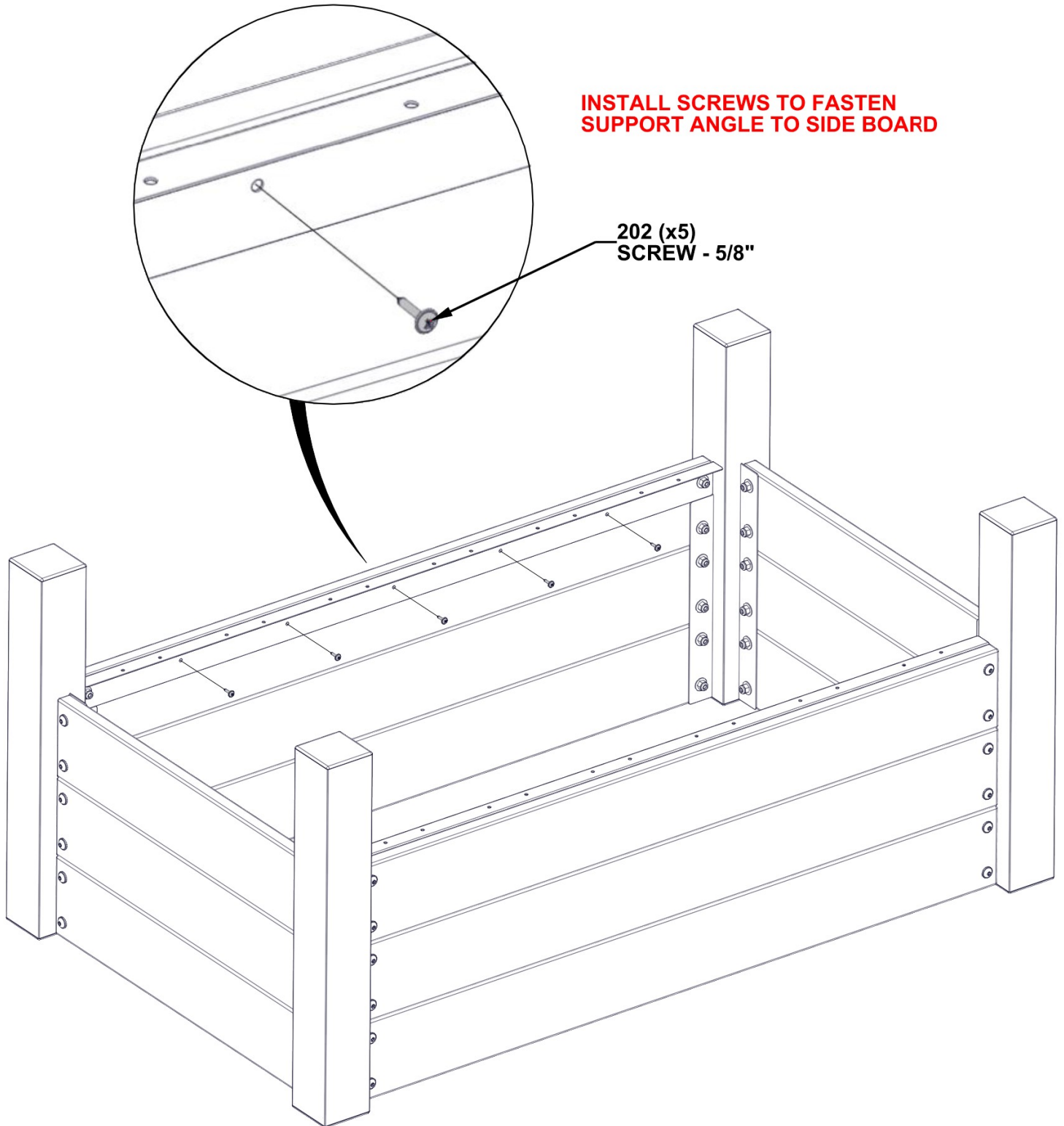

STEP 8 - PLANTER ASSEMBLY



G03 | SLAT-W4L16328
(x6) | 7/8"x4 3/4"x24 1/2" (22x120x623)

QTY	PART NUMBER	DESCRIPTION
24	H100202	SCREW PWH 8x5/8 BLK

202 (x24)
SCREW - 5/8"

**ALIGN PILOT HOLES IN SLATS WITH HOLES
IN SUPPORT BRACKET. SCREW IN PLACE.**

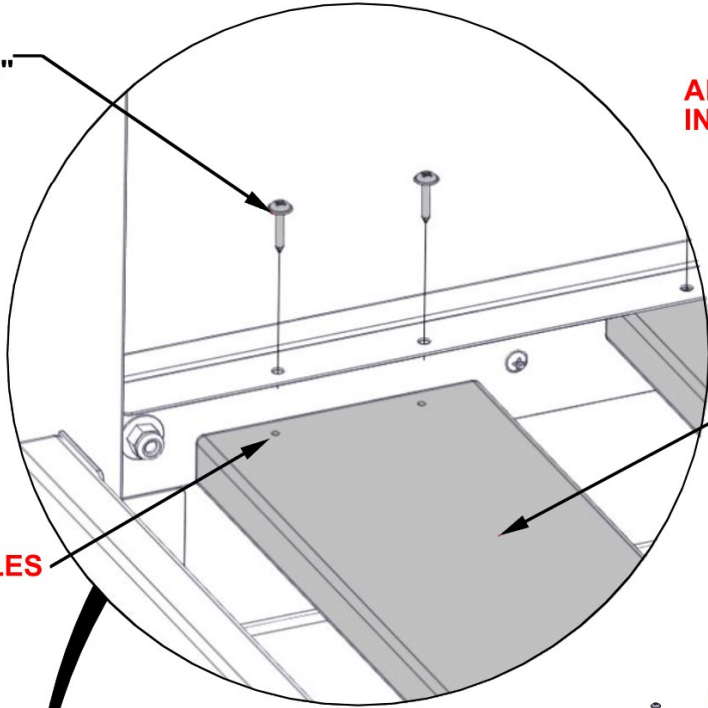

G03 (x6)
SLAT

NOTE: PILOT HOLES

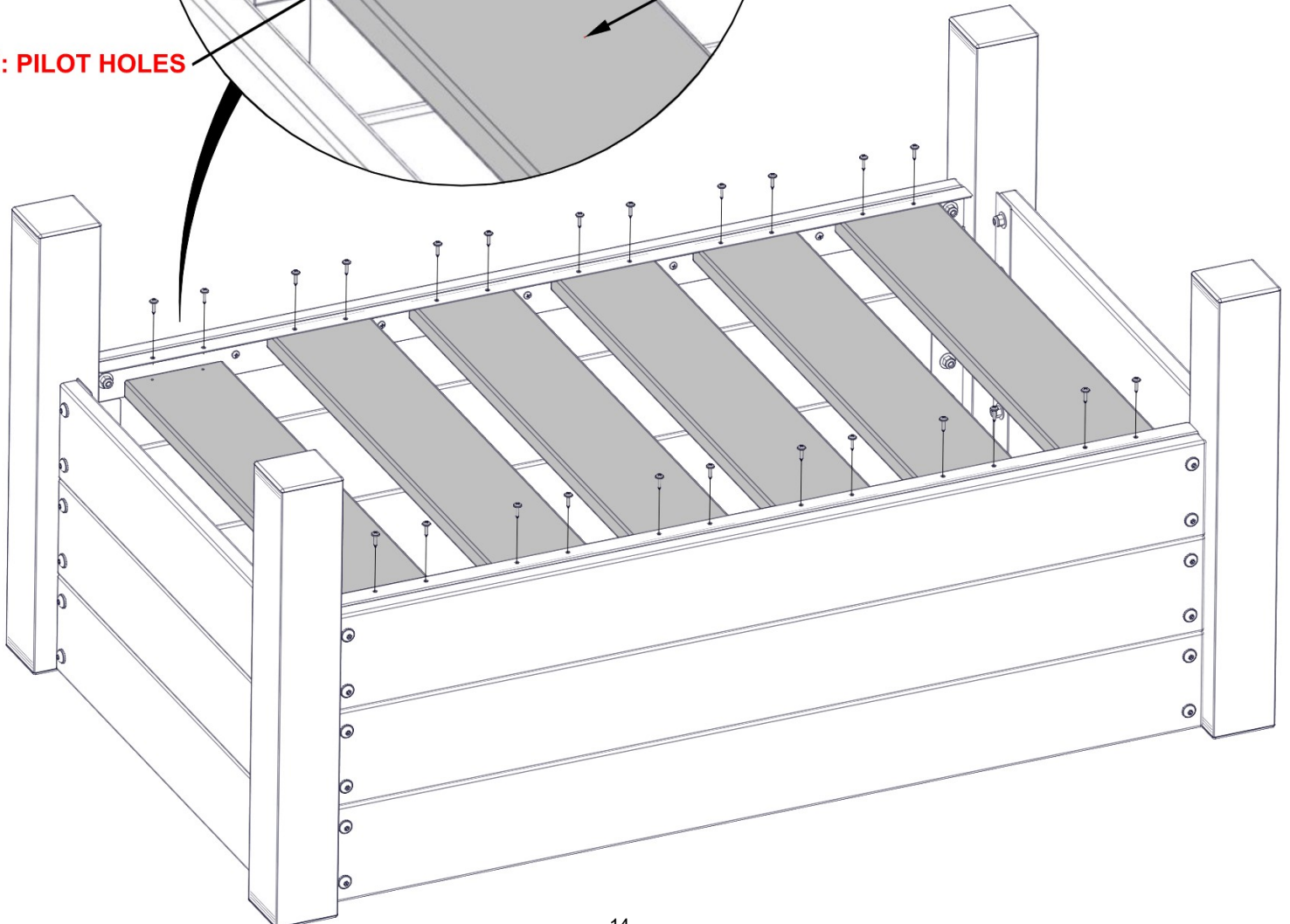

STEP 9 - PLANTER ASSEMBLY

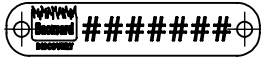

A4M01229 | PRODUCT NUMBER TAG
(x1)

QTY	PART NUMBER	DESCRIPTION
2	H100127	SCREW 4x1/2 BLK

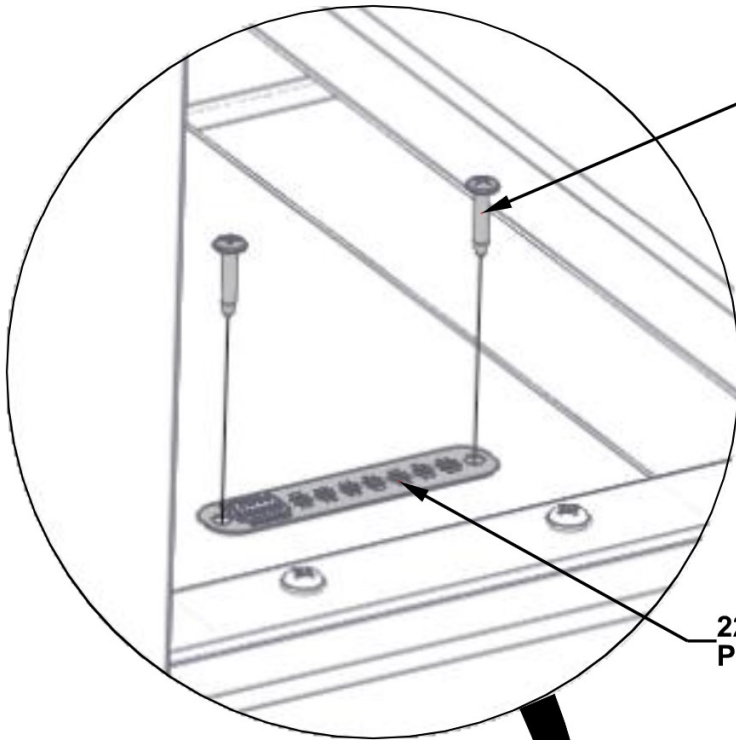

127 (x2)
SCREW - 5/8"

NOTES:
1. PLACE PRODUCT NUMBER TAG ON SLAT.
2. FASTEN IN PLACE AS SHOWN.

229 (x1)
PRODUCT NUMBER TAG

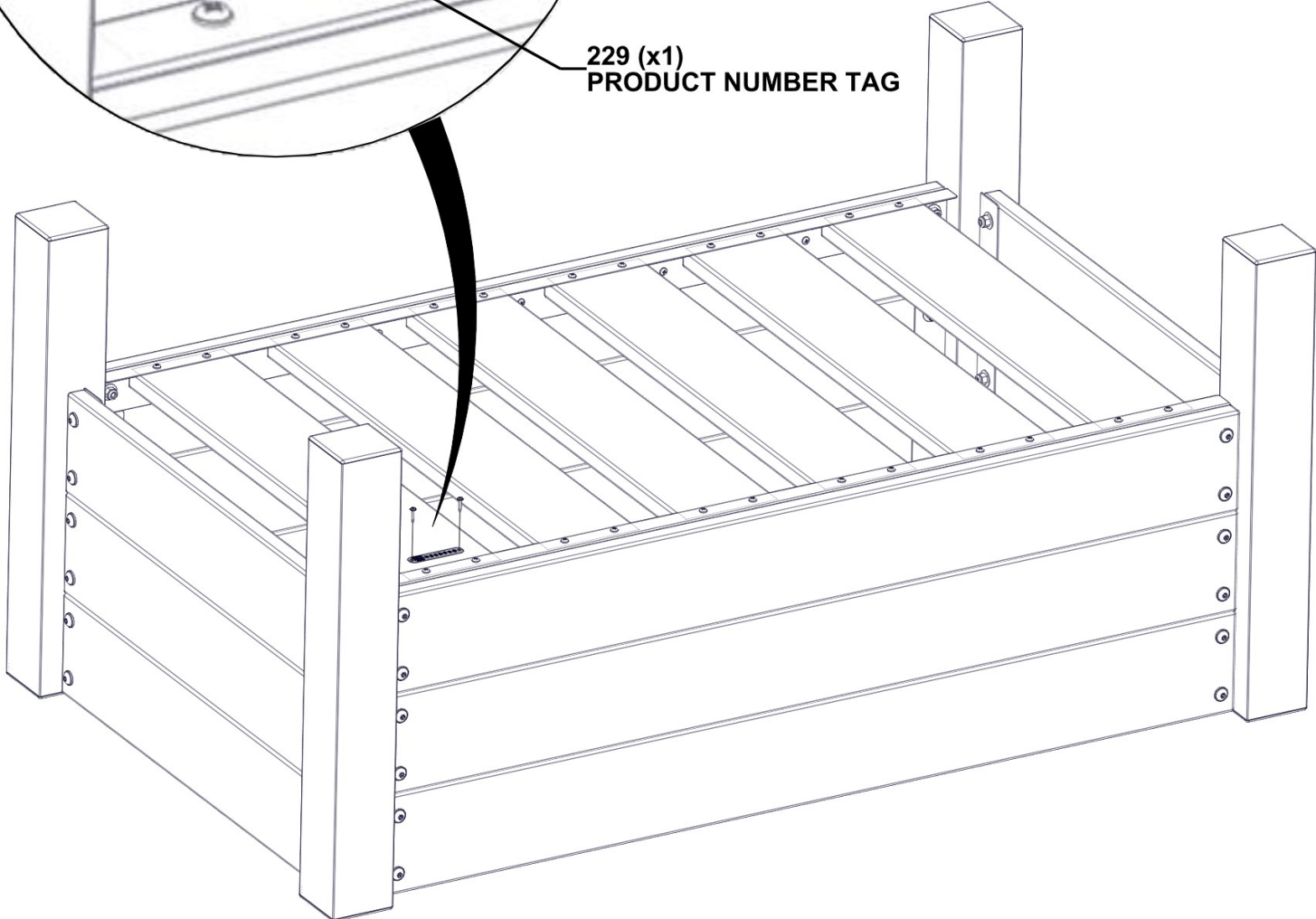

STEP 10 - PLANTER ASSEMBLY

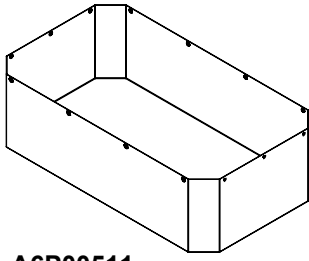

A6P00511 | PLANTER LINER
(x1)

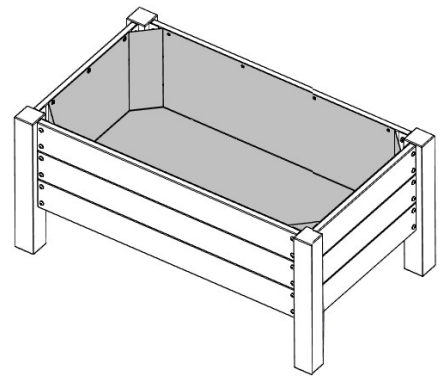

PLACE PLANTER LINER INTO PLANTER.

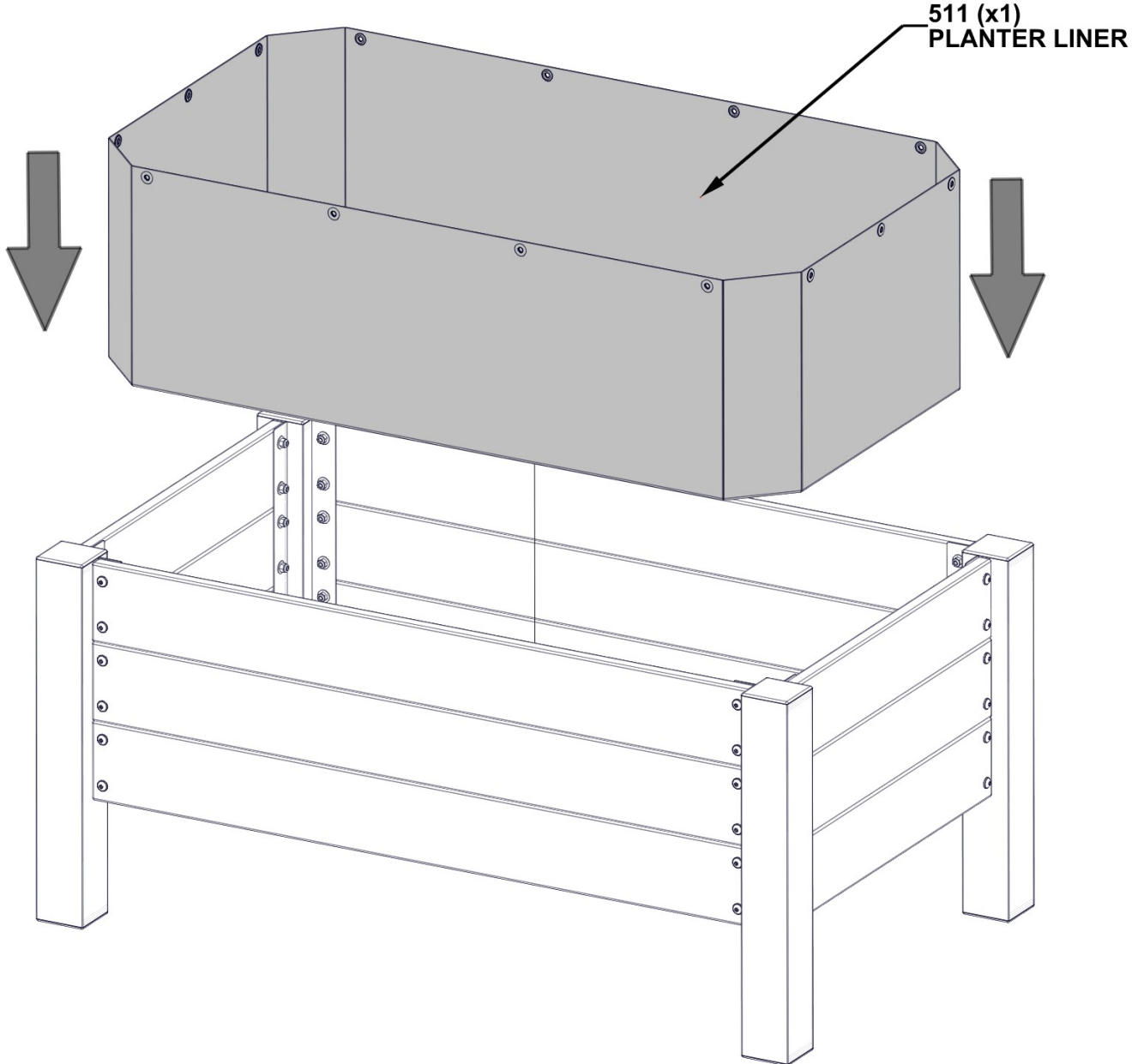

STEP 11 - PLANTER ASSEMBLY

QTY	PART NUMBER	DESCRIPTION
14	H100202	SCREW PWH 8x5/8 BLK

- NOTES:**
1. INSTALL PLANTER LINER BY PULLING CORNERS UP AGAINST EACH POST.
 2. TOP EDGE OF LINER SHOULD BE FLUSH WITH TOP OF BOARD.
 3. SCREW LINER IN PLACE AS SHOWN.

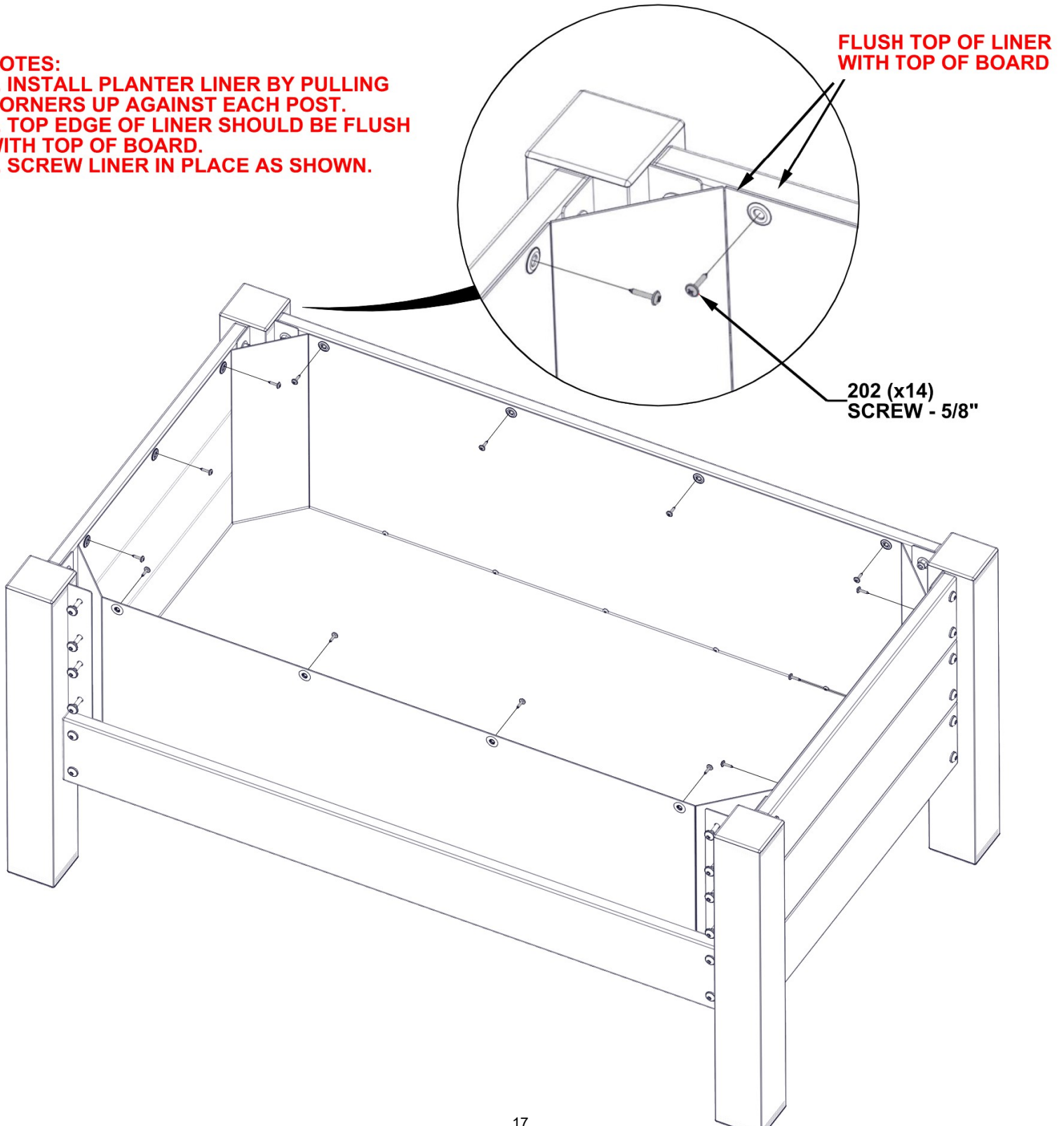

STEP 12 - PLANTER ASSEMBLY



A100241
(x1) | BYD ID TAG

QTY	PART NUMBER	DESCRIPTION
2	H100202	SCREW PWH 8x5/8 BLK

CENTER ID TAG AS SHOWN

